

PORTA-DOCK, INC.

A59 APD & A86 CPD 5'X 16' SW ALUMINUM PORTA-DOCK

For Beige Decking Add the Letter B to model

Thank you for purchasing our product!

***Please read these instructions and follow them step by step. ***

Step 1. Block up both ends of dock about 16". Bolt on winches (**REF # 11**) to the winch plate with the winch handle shaft to the outside using 3/8" x 1" bolts and nuts (**REF # 18 & 2**).

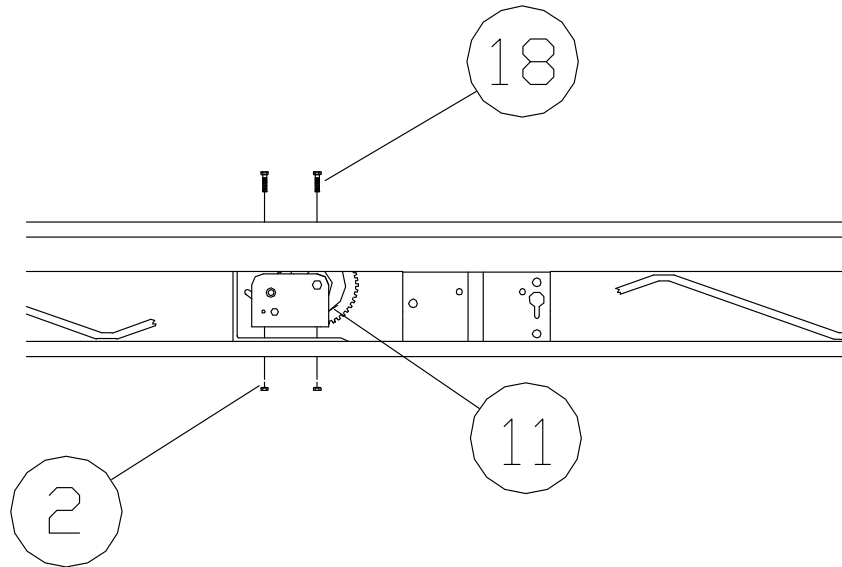

Step 2. Apply the four nylon wear strips (**REF # 29**) to the inside narrow ends of the vertical lift member pockets. Pockets should be clean and dry and above 50 degrees. Slide a VLM cover plate (**REF # 38**) onto each vertical lift member. Attach dock pulleys (**REF # 14**) with 1/2" x 2 1/2" bolts and nuts (**REF # 15 & 3**) to top of vertical lift members (**REF # 7**). Insert vertical lift members into pockets on each side of dock. Screw in set screw (**REF # 6**) into the face of the pockets. Leave all set screws loose at this time.

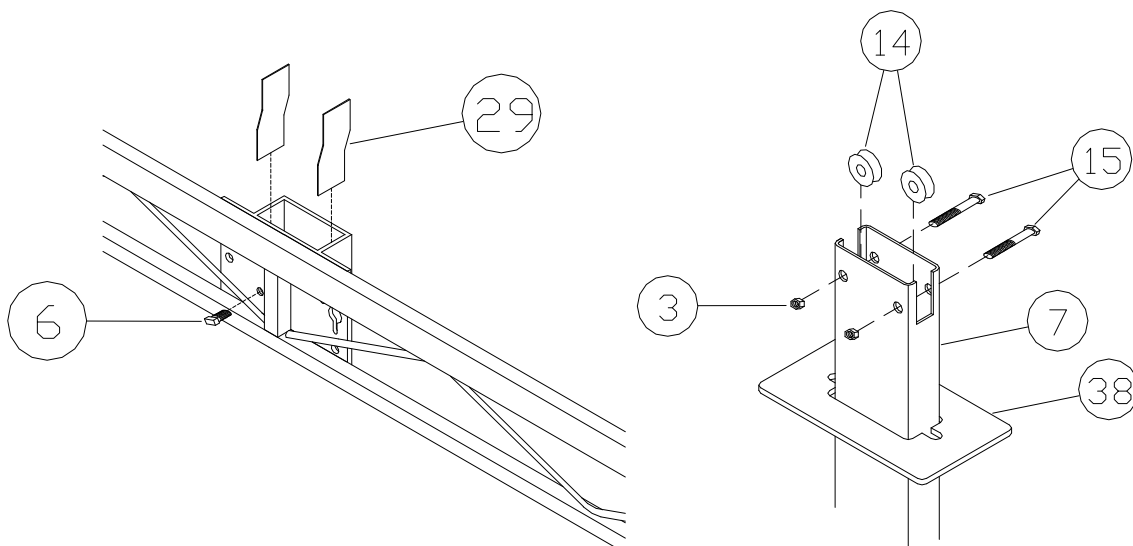

Step 3. Attach the chains (**REF # 16**) to the two farthest inside holes of the axle (**REF # 10**) with 3/8" x 3" bolt and nut (**REF # 19 & 2**). Next, slide on the vertical lift member brackets (**REF # 13**) onto axle, then spacing collars (**REF # 8**), then wheels (**REF # 4**) with the hub to the inside. Place the 1/4" X 2 1/2" pin (**REF # 1**) in the holes in the ends of the axle. Roll axle under dock, keeping axle centered with dock. Bolt vertical lift member brackets (**REF # 13**) to vertical lift members (**REF # 7**) with 3/8" x 3" bolts, 3/8" washers, and nuts (**REF # 19, 20, & 2**) so there is a bracket on each side of the lifting member. Bring end of chain up to the opposite side of dock through the keyhole located on the right side of pocket and lock in position by sliding the chain link down the keyhole slot.

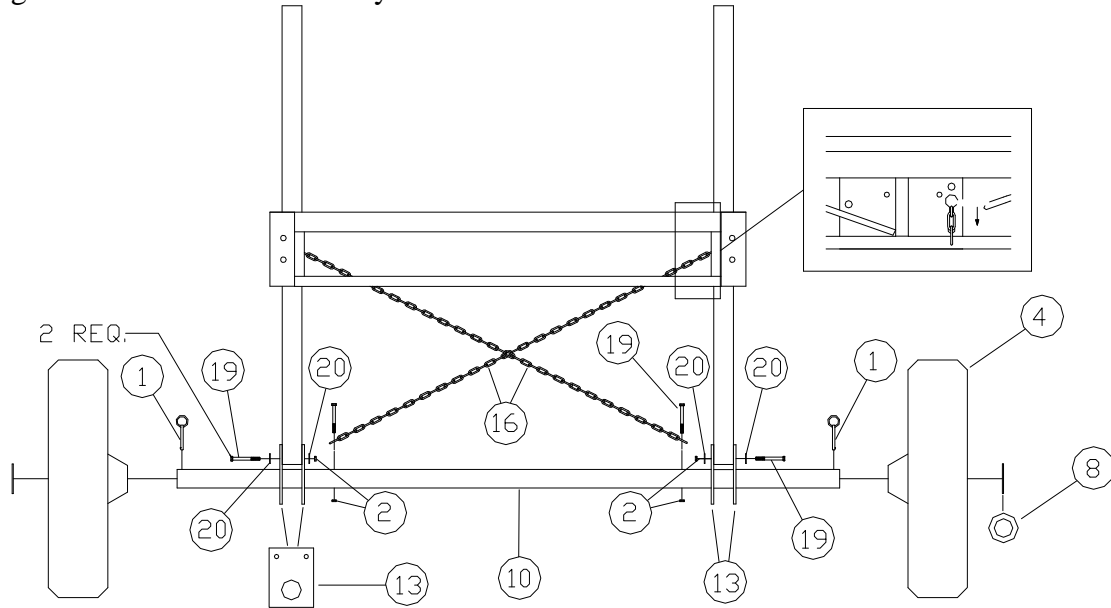

Step 4. Attach winch handles (**REF # 28**) with winch nut (**REF # 29**). Attach lower dock pulleys (**REF # 14**) between pocket and ear tab located on the winch side of the vertical lift member pocket with 1/2" x 2 3/4" clevis and cotter pins (**REF # 21 & 17**). Starting winch cable (**REF # 12**) from the outside of the winch, pass cable through the hole on the side of the drum with the gears. Run the cable through lower pulley, then up to pulleys on vertical lift members, and down to the top 13/32" hole in the pocket and back through the bottom 13/32" hole. Fasten with cable clamp (**REF # 5**). Work winches until cables are raising dock. You must alternate winches as the dock moves up or down and you must have *slack in the chain when raising*.

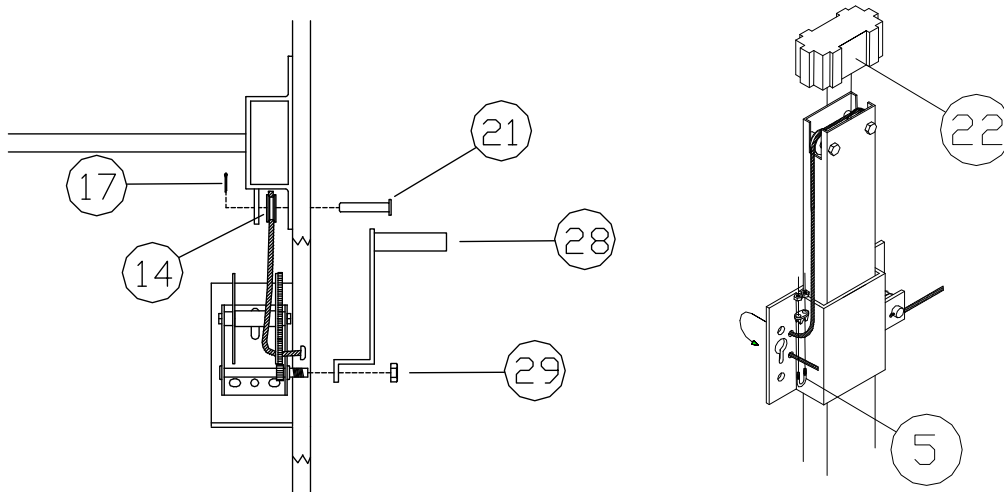

Note: On APD Models, run foam tape on both sides of dock frame.

Before moving your dock into the water, make sure that the chains are not wrapped around the axle, and then pull the slack out of the chains by hooking them into the keyhole bracket. Roll your dock into position, and loosen the set screws on the VLM pocket. Adjust the dock to the desired height making sure that there is enough slack in the chains to accommodate the height you will be adjusting to. Once the desired height is reached, pull both the chains tight and then lower one side of the dock so the next link can be hooked into the keyhole slot and raise the dock back up to complete the tightening of the chain. Repeat on the other side. When finished with this, there should be no visible slack left in the chains, and they should be tight enough that you can't move them. Tighten the set screws in the VLM pocket.

The cross chains are to help control the side-to-side stability of the end of the dock and need to be tight. Once set they only need to be adjusted if the height of the dock is changed.

WARNING: before raising the dock it is necessary to loosen both of the chains and the set screws, or serious damage to the dock may occur. When tightening the set screws, they should be tightened until they are snug against inside leg, and then tightened 1 1/2 to 2 turns more. Check the set screws after a couple of uses and retighten if necessary.

When moving dock into and from lake, lower dock to lowest level possible.

PARTS LIST**A59 APD & A86 CPD 5'X16' SW ALUMINUM PORTA-DOCK**

REF. #	PART #	DESCRIPTION	CPD	APD
1	5245	1/4" X 2 1/2" PIN	2	2
2	5056	3/8" NUT	8	8
3	5058	1/2" NUT	4	4
4	4002	TIRE PLASTIC MOLDED	2	2
5	5003	3/16" CABLE CLAMP	2	2
6	5170	1/2" X 3/4" SET SCREW	2	2
7	30084	VERTICAL LIFT MEMBER	2	2
8	5077	WASHER 3"	2	2
9	10200	DOCK CONNECTOR BRACKET	2	2
10	30180	AXLE	1	1
11	3005	WINCH DL 1100	2	2
12	3050	CABLE 3/16" X 15'	2	2
13	30088	LIFT MEMBER BRACKET	4	4
14	3300	PULLEY SHEAVE 1 1/2"	6	6
15	5120	1/2" X 2 1/2" BOLT	4	4
16	3090	CHAIN 3/16" X 8'	2	2
17	5025	1/8" X 1" COTTER PIN	2	2
18	5081	3/8" X 1" BOLT	6	6
19	5084	3/8" X 3" BOLT	6	6
20	5070	3/8" WASHER	8	8
21	5008	1/2" X 2 3/4" PIN	2	2
22	3804	VLM PULLEY COVER	2	2
25	F94	FRAME 5' X 16' APD/CPD WH END	1	1
	B95(B)	AL PANEL 5' SW CUTOUT	-	2
	B13(B)	AL PANEL 5' STRAIGHT	-	2
	B53	CEDAR PANEL STRAIGHT	2	-
	B50	CEDAR PANEL DOUBLE CUT	2	-
27	3008	DL WINCH HANDLE	2	2
28	5066	DL WINCH NUT	2	2
29	4112	8 1/2" VLM WEAR PAD	4	4
30	4108	APD FOAM TAPE-16' ROLL	-	3
31	F94	FRAME AL 5 X 16' WHEEL END	1	1
38	3850	VLM COVER PLATE APD WHITE	-	2
	3851	VLM COVER PLATE APD BEIGE	-	2
	3852	VLM COVER PLATE CPD BROWN	2	-



Wheel dock height adjustment instructions

Before moving your dock into the water, make sure that the chains are not wrapped around the axle, and then pull the slack out of the chains by hooking them into the keyhole bracket. Roll your dock into position, and loosen the set screws on the VLM pocket. Adjust the dock to the desired height making sure that there is enough slack in the chains to accommodate the height you will be adjusting to. Once the desired height is reached, pull both the chains tight and then lower one side of the dock so the next link can be hooked into the keyhole slot and raise the dock back up to complete the tightening of the chain. Repeat on the other side. When finished with this, there should be no visible slack left in the chains, and they should be tight enough that you can't move them. Tighten the set screws in the VLM pocket.

The cross chains are to help control the side-to-side stability of the end of the dock and need to be tight. Once set they only need to be adjusted if the height of the dock is changed.

WARNING: before raising the dock it is necessary to loosen both of the chains and the set screws, or serious damage to the dock may occur. When tightening the set screws, they should be tightened until they are snug against inside leg, and then tightened 1 1/2 to 2 turns more. Check the set screws after a couple of uses and retighten if necessary.

When moving dock into and from lake, lower dock to lowest level possible.

Porta-Dock, Inc.