

PORTA-DOCK, INC.

WHEEL DOCK ALUMINUM DOCK STEPS

L50 - 4 STEP *** L53 - 6 STEP *** L54 - 8 STEP

Thank you for purchasing our product!

Please read these instructions and follow them step by step.

Step 1. First locate your right & left sides (**REF. # 2A & 2B**) and the Alum. Dock Steps (**REF. # 4**). Attach steps to side frames using 1/4 X 3/4" carriage bolt, lock washers & nuts (**REF. # 8, 11 & 12**). **Note:** Keep bolts loose until all steps are attached. Tighten until the head of the carriage Bolts are flush with the dock steps.

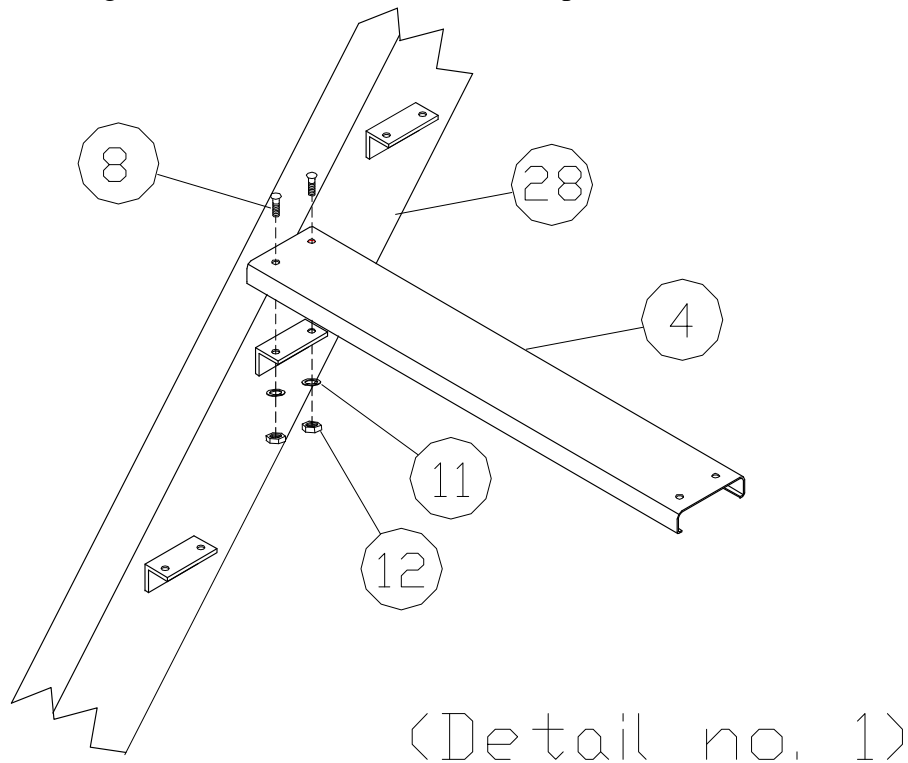

Step 2. Attach footpad onto bottom of leveling leg tube (**REF. # 7 & 3**) with 3/8"X 2 1/2" bolt, washers & locknut (**REF. # 15, 16 & 18**). Footpad should be able to swivel freely. Insert your dock step leveling leg tube into the lower side frame pocket & secure with a 1/2" X 1" set screw (**REF. # 14**). Finger tighten at this time. (**See detail no.2**).

Step 3. Locate bottom rail upright arms (**REF. # 6**) & insert into the lower pockets of the side frame & secure with 1/4" X 2" carriage bolt, 1/4" flat washers & acorn nut (**REF. # 9, 10 & 13**). Follow the same procedure for the top railing upright arms (**REF. # 5**). Secure the handrail (**REF. # 1**) to the lower & top upright arms with 1/4" x 2" carriage bolt, 1/4" washer & acorn nut (**REF. # 9, 10 & 13**). Slide end caps (**REF. # 17**) on hand rail tubes. (**See detail no.2**).

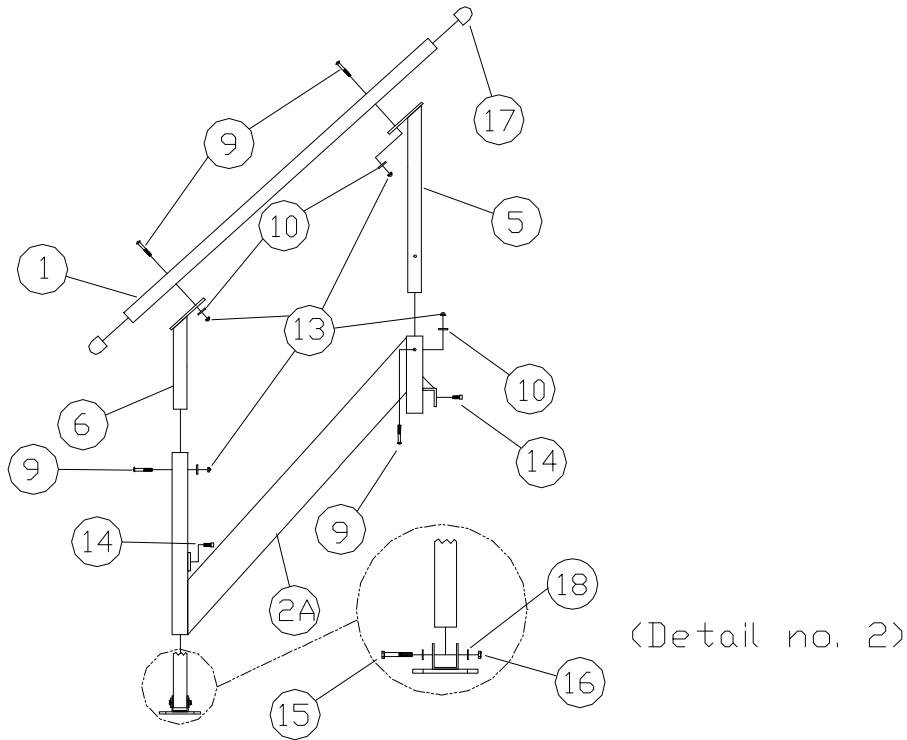

Step 4. Place the hook bracket that is on the top of the dock steps over the bottom tube of the dock. Secure in place with 1/2" X 1" set screws. Adjust the bottom leveling leg tube until your dock steps are approximately level. Tighten setscrews at this time.

REF. #	PART NO.	DESCRIPTION	<u>L50</u>	<u>L53</u>	<u>L54</u>
			4 STEP QTY	6 STEP QTY	8 STEP QTY
1	30705	RAILING 4 STEP	2	-	-
	30716	RAILING 6 STEP	-	2	-
	30717	RAILING 8 STEP	-	-	2
2A	E35	4 STEP RIGHT SIDE	1	-	-
2B	E36	4 STEP LEFT SIDE	1	-	-
	E95	6 STEP RIGHT SIDE	-	1	-
	E96	6 STEP LEFT SIDE	-	1	-
	E97	8 STEP LEFT SIDE	-	-	1
	E98	8 STEP RIGHT SIDE	-	-	1
3	30706	STEP LADDER LEV.LEG TUBE	2	2	2
4	30711	STEP WITH NON SKID TAPE	4	6	8
5	E33	TOP RAILING UPRIGHT ARMS	2	2	2
6	E32	BOTTOM RAILING UPRIGHT ARMS	2	2	2
7	E34	DOCK STEP FOOT PADS	2	2	2
8	5150	1/4"X 3/4" CARRIAGE BOLT	16	24	32
9	5181	1/4"X 2" CARRIAGE BOLT	8	8	8
10	5075	1/4" FLATWASHER	8	8	8
11	5076	1/4" LOCK WASHER	16	24	32
12	5055	1/4" NUT	16	24	32
13	5041	1/4" ACORN NUT	8	8	8
14	5174	1/2"X 1" SET SCREW	4	4	4
15	5083	3/8"X 2 1/2" BOLT	2	2	2
16	5038	3/8" NYLOCK NUT	2	2	2
17	3810	1 1/2" SQ. CAPS	4	4	4
18	5070	3/8" WASHER	4	4	4