

## **PORTA-DOCK, INC.**

### **L95 4' DS WHEEL KIT BOLT ON / L96 5' WHEEL KIT BOLT ON**

**Thank you for purchasing our product.**

**Please read these instructions and follow them step by step.\***

**STEP 1.** Locate the two wheel kit side plates (**REF. # 4**).

Apply the two nylon wear strips (**REF. # 8**) to the pocket on each side plate as shown. **NOTE: DO NOT PUT THE WEAR STRIP ON THE POCKET SIDE THAT HAS THE SET SCREW HOLES.** Pockets should be clean and dry with a temperature above 50 degrees. Bolt the side plates to each side of the dock, near the end of the dock or a cross member. Attach using 3/8" X 2 1/2" bolts, washers, aluminum backer angle and nuts. (**REF. # 13, 11, 6 & 10**)

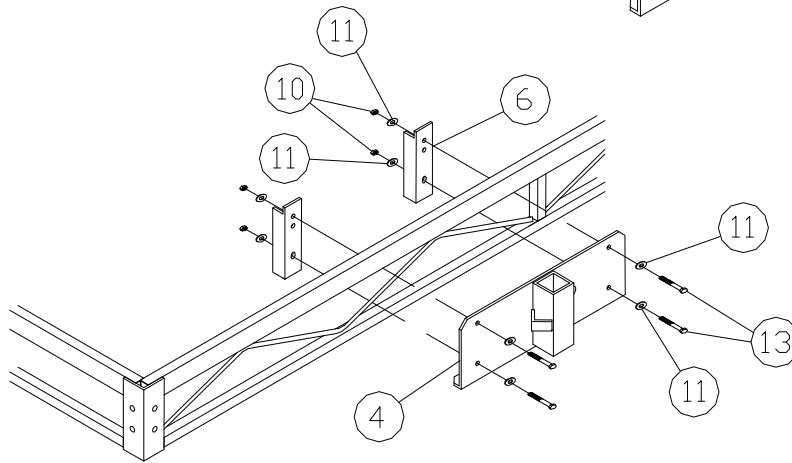
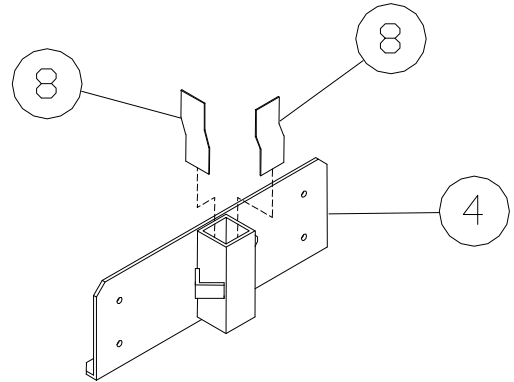

**STEP 2.** Drop vertical lift member (**REF. # 1**) with holes down and parallel to dock, into the two side plate pockets. Bolt the two lift member brackets (**REF. # 5**) to each side of the vertical lift member, using 3/8" X 3" bolts and nuts (**REF. # 14 & 10**). Leave the nuts loose at this time. Place the setscrews (**REF. # 16**) into the face of each pocket. Place a 2" square gray cap (**REF. # 7**) onto the top of each vertical lift member.

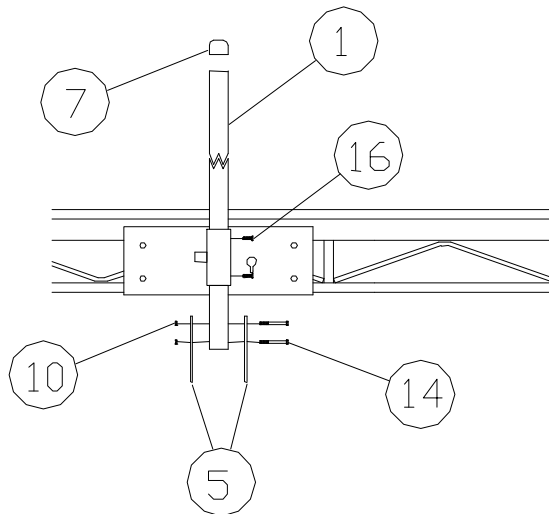

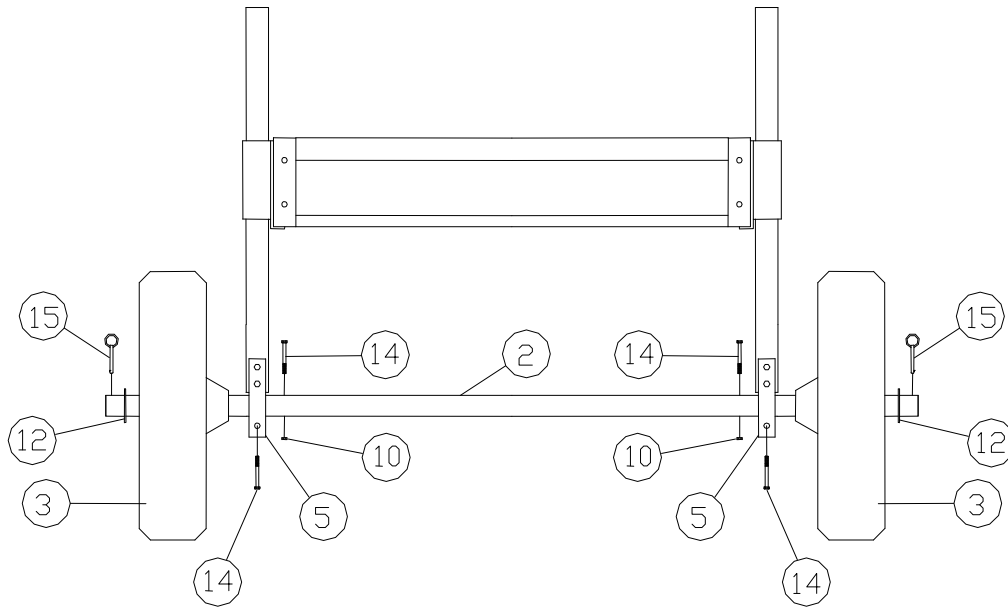

**STEP 3.** Find the axle (**REF. # 2**) and place a 3/8" X 3" bolt and nut (**REF. # 14 & 10**) into the 7/16" holes on each end of the axle. Slide the dock wheel (**REF. # 3**) with the hub to the inside onto the axle. Slide on a 3" washer (**REF. # 12**). Put 1/4" X 2 1/2" pin (**REF. # 15**) through holes on each end of axle. Roll axle under dock, keeping axle centered with dock. Lower lift members onto top of axle. Fasten in place with the third 3/8" X 3" bolt (**REF. # 14**) through lift member brackets (**REF. # 5**). Tighten all three bolts on each one.

**NOTE:** For maximum stability tighten the bolts until the steel VLM brackets bend in.

### PARTS LIST

#### L95 4' WHEEL KIT BOLT ON - L96 5' WHEEL KIT BOLT ON

<b>REF. #</b>	<b>PART #</b>	<b>DESCRIPTION</b>	<b>QTY</b>
1	30095	VERTICAL LIFT MEMBER	2
2	30183	AXLE 72" - 4' DOCK	1
2a	30184	AXLE 82" - 5' DOCK	1
3	4002	PLASTIC TIRE	2
4	F31	SIDE PLATE FOR WHEEL KIT	2
5	10003	STEEL VERTICAL LIFT MEMBER BRACKET	4
6	20060	ALUMINUM BACKER ANGLE	4
7	3821	GRAY CAP 2" SQ.	2
8	4112	NYLON WEAR STRIP	4
9	5041	ACORN NUT 1/4"	2
10	5056	NUT 3/8"	16
11	5070	WASHER 3/8"	16
12	5077	WASHER 3"	2
13	5083	BOLT 3/8" X 2 1/2"	8
14	5084	BOLT 3/8" X 3"	8
15	5245	PIN 1/4" X 2 1/2"	2
16	5174	SETSCREW 1/2" X 1"	4